

EST. 1936

KATRADIS GROUP OF COMPANIES

SACRIFICIAL ANODES
ANCHORS & ANCHOR CHAINS
VESSEL DECK EQUIPMENT

QUALITY PRODUCTS / PASSION FOR PERFECTION



EST. 1936

KATRADIS GROUP OF COMPANIES

KATRADIS GROUP OF COMPANIES 80 years strong relationships!

Katradis Group of Companies has a long and distinguished history which goes back to the first half of the twentieth century. The company was established in 1936 by Konstantinos Katradis, operating back then as a ship supplier specializing in high quality mooring ropes.

Currently in the hands of a third generation member of the Katradis family, the company has since then become a pioneer in the field of manufacture of mooring ropes and anodes for sacrificial protection, serving the marine industry as well as the sectors of offshore, aquaculture, fishing and yachting.

Over the years we have developed extensive expertise in the design and development of synthetic mooring ropes, which are our mainline products. Our rope factory in Greece, whose site covers an area of 30000m², is one of the most technologically advanced factories in Europe, manufacturing top quality ropes such as Double braided, Sirius UHMWPE (ULTRA High Molecular Polyethylene), Kevlar (aramid), LCP (Liquid Crystal Polymer) and others.

We also supply a wide range of steel wireropes for shipping, fishing and industrial purposes. Our steel wireropes comply with the requirements set by ABS, API (American Petroleum Institute), GL and Lloyd's Register.

Responding to a more recent customer demand our company has gone on to manufacture **zinc** and **aluminum anodes** such as **Hull anodes**, **Tank anodes**, **Pit guard anodes**, all of which are made in our highly specialized factory.

Furthermore, the Katradis group boasts a large stock of **deck equipment** such as **anchors**, **stud link anchor chain cables**, **container fittings**, **alloy steel chain slings**, **lifting slings** and lashing webbings as well as **port development equipment** such as **fenders**, **buoys**, **floating marinas**, **bollards** and **oil booms**.

ANODES

What an anode does for your vessel:

- it protects and extends the lifetime of every metallic object in contact with it, when in a sea environment
- it works where there is no paint or bad quality paint on a metallic surface
- it works where there is corrosion under the paint layer
- it saves money from corroded parts and frequent repairs

Principle of cathodic protection

Corrosion is the spontaneous chemical reaction of a metal against its surroundings. Particularly, in sea water this chemical reaction proceeds by an electrochemical mechanism involving oxidation of the metal, which results in metal loss. That happens when we have a plate with pitting appearance, at the spots where the coating is not good enough to protect.

The part of the metal surface in the electrochemical mechanism (electron release) is called anodic. On the other part of the metal surface where the electron consumption takes place is called cathodic.

If we can supply electrons from an external source, then the electron consumption (cathodic) will speed up and the electron release (anodic) reaction will slow down. As a consequence, the rate of iron dissolution will slow down and the electrode potential will decrease. From the procedure above, the Principle of cathodic protection can be derived from supplying electrons into the metal from an external source, so we can slow down its dissolution.

Applications of anodic protection

The delivery of the electrons to the metal surface to be protected can be achieved in two ways. Firstly, by using an impressed current technique and secondly by using sacrificial anodes.

The impressed current method

By this method the electrical current is delivered to the metal surface from a D.C. power source through an auxiliary anode i.e. the current is forced in or impressed.

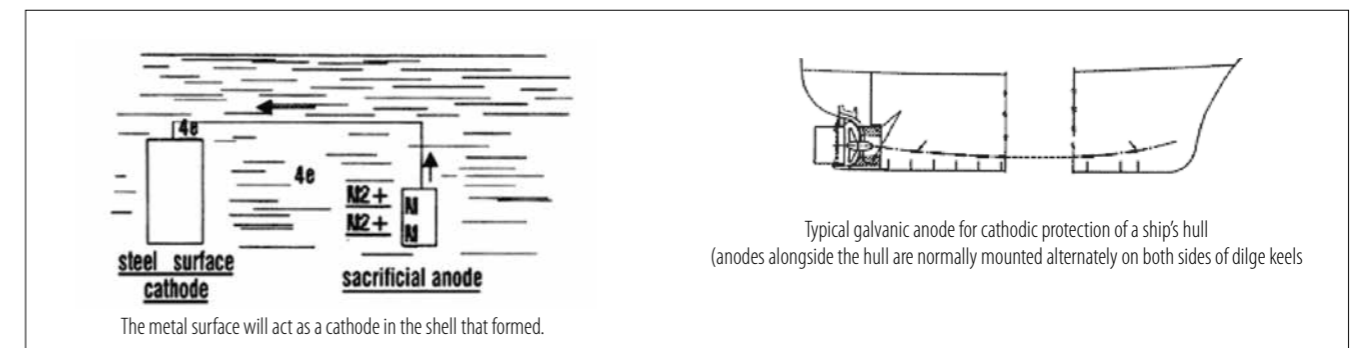

The sacrificial anode method

By this method a galvanic cell is formed between the structure to be protected and the sacrificial anode. The electrons pass spontaneously from the anode to the metal surface (cathode). Thus, the source of the electrons (the sacrificial anodes) must have a more negative electrode potential than the metal surface. Metals and conducting materials commonly used are listed below in such order that each normally act as anode with respect to all the materials which follow it.

MAGNESIUM, ZINC, ALUMINUM, IRON AND STEEL, LEAD, BRASS, COPPER, GRAPHITE, COKE E.T.A.

This explains why magnesium, aluminum and zinc alloys are used to protect steel today.

CALCULATIONS

External Protection

The number of anodes for the protection of the hull is calculated based on the following criteria:

A. CURRENT REQUIREMENTS

The wetted surface of the hull times protective current density.

$$\text{Current (Amp)} = \frac{\text{Protected area (m}^2\text{)} \times \text{current density (mA/m}^2\text{)}}{1000}$$

A. SYSTEM DESIGN FILE

The total weight of anode material required is:

$$\text{Weight (kg)} = \frac{\text{Current (Amps)} \times \text{design life (years)} \times 8766}{\text{Capacity of material (Amph/kg)} \times 0,9}$$

As a result the number of anodes selected must at least satisfy both the total current and total weight requirements as follows:

$$\text{NUMBER OF ANODES} = \frac{\text{CURRENT REQUIRED}}{\text{INDIVIDUAL CURRENT OUTPUT}}$$

$$\text{NUMBER OF ANODES} = \frac{\text{WEIGHT REQUIRED}}{\text{INDIVIDUAL NET ANODE WEIGHT}}$$

ANODE LOCATION

The calculated anodes must be installed in equal distances around the hull, about 6 meters apart. The 15% - 20% of the total calculated QTY must be installed to the stern and rudder area of the vessel. The anodes should not be mounted in the zone close to the propeller's edges.

INTERNAL CATHODIC PROTECTION

The cathodic protection of the ship's tanks is effected with sacrificial anode system. Of course, this type of protection can be applied only to water ballast or cargo/ballast tanks. Zinc aluminum or magnesium anodes may be used but for the installation precautions must be taken for avoiding hydrogen evolution (in the case of magnesium) and sparking (in the case of aluminum). The final selection of the alloy to be used will also depend on the ballast water (seawater), the compatibility of the alloy with any cargo, which might be carried in the tank, the size of the protected tank and the type of the vessel.

Current density required for protection

In case, the tank surface is being painted, the anodes will be installed to suppress corrosion on any area with paint defects. The current density of 5mAmp/m² is normally adequate. In case, of non-coated surface the following current densities are recommended:

FORE AND AFT PEAK TANK	108mAmp/m ²
TOP SIDE TANKS	120mAmp/m ²
DOUBLE BOTTOM TANKS	86mAmp/m ²
CARGO/CLEAN BALLAST TANK	86mAmp/m ²
LOWER WING TANKS	90mAmp/m ²

The system life should be at least four (4) years. The above-recommended current densities are applicable to ships for which the normal ballast trip is longer than approx. 5 days. In case the trip is shorter than 5 days, then the above densities should be increased by 20%.

Methods for Hull and Tank Anodes installations

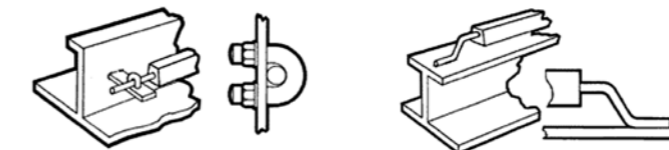
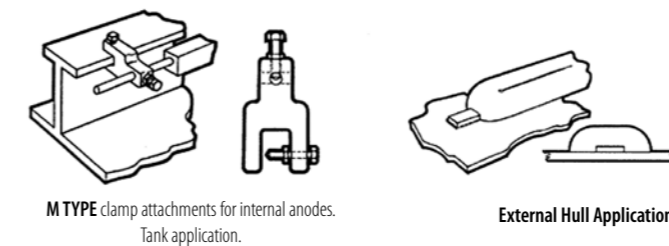

THE RECIPIES FOR ZINC AND ALUMINUM ANODES

Specification Code	US MIL SPEC A18001J
Cu	0.005 max
Al	0.10 - 0.50
Fe	0.005 max
Cd	0.025 - 0.07
Pb	0.006 max
Zn	REMAINDER
POTENTIAL Ag / AgCl (mV)	-1050
ELECTROMECHANICAL CAPACITY (Amp. Hours / kg)	780

Specification Code	
Fe	0.15 max
Si	0.05 - 0.20
Zn	3.50 - 5.00
Ti	0.01 - 0.05
In	0.02 - 0.05
Mn	0.15 - 0.50
Cu	0,01 max
Al	REMAINDER
POTENTIAL Ag / AgCl (mV)	-1100
ELECTROMECHANICAL CAPACITY (Amp. Hours / kg)	2700

HULL ANODES

ZINK HULL ANODES

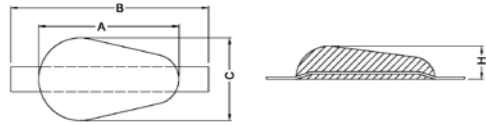

ANODE TYPE	DIMENSIONS (mm)				WEIGHT (kg)		INSERT (mm)
	A	B	C	H	NET	GROSS	
N30ZH	170	240	100	40	2.7	3.0	30 x 3
N75ZH	300	400	160	35	7.0	7.5	40 x 6
N95ZH	300	400	160	45	8.6	9.5	50 x 6

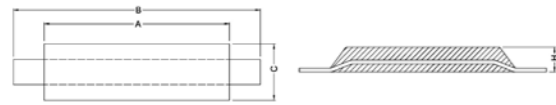

ANODE TYPE	DIMENSIONS (mm)				WEIGHT (kg)		INSERT (mm)
	A	B	C	H	NET	GROSS	
N55ZH	300	400	90	40	5.0	5.5	40 x 6
N125ZH	465	565	110	40	12.0	12.5	40 x 6
N165ZH	520	620	120	40	15.3	16.5	50 x 6
N230ZH	680	780	128	40	21.5	23.0	50 x 6

ALUMINIUM HULL ANODES

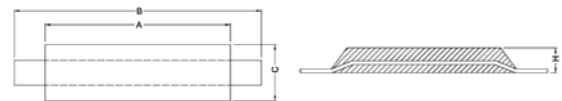

ANODE TYPE	DIMENSIONS (mm)				WEIGHT (kg)		INSERT (mm)
	A	B	C	H	NET	GROSS	
N30AH	300	400	90	40	2.3	3.0	40 x 6
N55AH	460	560	110	40	4.6	5.5	50 x 6
N80AH	520	620	120	40	7.0	8.0	50 x 6
N105AH	680	780	128	40	9.3	10.5	50 x 6
N125AH	800	900	120	40	11.0	12.5	50 x 6
N155AH	1000	1100	120	45	13.5	15.5	50 x 6



All weights and dimensions are subject to normal variations in material densities.
A range of standard zinc or aluminium anodes is illustrated above, alternative configurations may be cast to requirements.

TANK ANODES

ZINC TANK ANODES

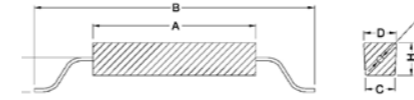

ANODE TYPE	DIMENSIONS (mm)						WEIGHT (kg)	
	B	A	C	D	H	F	NET	GROSS
N120ZT	950	570	65	68	56	12	10.8	12.0
N230ZT	1500	1100	65	68	56	14	21.5	23.0
N320ZT	1600	1200	60	63	63	14	30.5	32.0

ZINC PITGUARD TANK ANODES

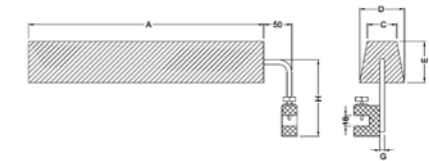

ANODE TYPE	DIMENSIONS (mm)							WEIGHT (kg)	
	A	H	C	D	E	F	G	NET	GROSS
N100ZPG	500	56	65	68	70	35	14	8.8	10

ALUMINIUM TANK ANODES

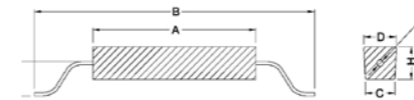

ANODE TYPE	DIMENSIONS (mm)						WEIGHT (kg)	
	B	A	C	D	H	F	NET	GROSS
N50AT	700	500	59	62	60	12	4.0	5.0
N100AT	1200	760	50	76	70	14	8.8	10.0
N140AT	1400	1200	60	64	60	14	12.5	14.0

ALUMINIUM PITGUARD TANK ANODES

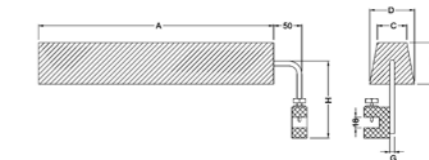

ANODE TYPE	DIMENSIONS (mm)							WEIGHT (kg)	
	A	H	C	D	E	F	G	NET	GROSS
N50APG	400	70	50	76	70	35	12	4	5.0
N70APG	600	64	60	64	70	35	14	5.9	7.0

TANK ANODES ARE AVAILABLE EITHER Z-CRANKED (AS SHOWN) OR WITH STRAIGHT INSERT. ALTERNATIVE INSERT ARRANGEMENTS AVAILABLE ON REQUEST.

BOLTED HULL ANODES

BOLTED ZINC HULL ANODES

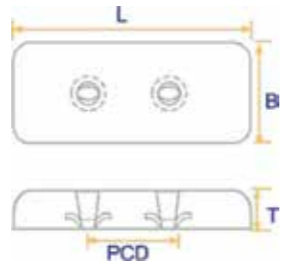

ANODE TYPE	DIMENSIONS (mm)				WEIGHT (kg)	
	L	B	T	PCD	NET	GROSS
N60ZBH	300	150	26	160	5.6	5.9
N75ZBH	300	150	32	160	7	7.3
N85ZBH	300	150	36	160	8	8.3
N100ZBH	300	150	46	160	9.7	10
N130ZBH	300	150	56	160	12.7	13
N220ZBH	300	150	82	160	21.7	22

BOLTED ALUMINIUM HULL ANODES

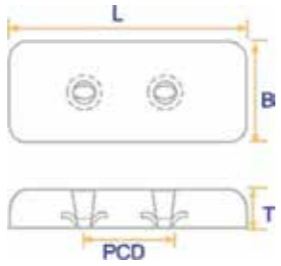

ANODE TYPE	DIMENSIONS (mm)				WEIGHT (kg)	
	L	B	T	PCD	NET	GROSS
N27ABH	300	150	26	160	2.4	2.7
N30ABH	300	150	32	160	2.6	2.9
N35ABH	300	150	36	160	3.2	3.5
N50ABH	300	150	46	160	4.3	4.6
N55ABH	300	150	56	160	5.2	5.5
N85ABH	300	150	82	160	8.2	8.5



ROUND ANODES

ZINC CASTING ROUNDS

L=600 MM

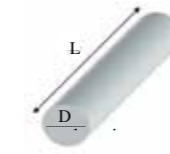

D (MM)	20	25	30	40	50	60	70	80	90	100	110	120	130	150
WEIGHT (KGS)	1.4	2.1	3.0	5.0	8.2	11.0	16.0	21.0	27.0	32.0	44.3	48.0	57.0	76.0

For updated information please check regularly our website <http://www.katradis.com/anodes>

PRODUCTION PROCEDURE



SPECIAL ORDERS:

We also provide the option of manufacturing special molds that meet particular standards of the market.

ANCHOR CHAINS & ANCHORS

We supply from the smallest to largest sizes of chains and accessories with grades (U1, U2, U3), which are accompanied with the major class certificates. Also we supply anchors, mainly the most commonly used ones, hull type, but we can provide, at notice any type needed. Comprehensive stocks of new and second hand anchors and chains are held in Piraeus, China and this stock allows KATRADIS to provide the quickest delivery service possible worldwide.

Prompt service within 24 hours

Our large stock of studlink chains and anchors, in Greece and overseas, for prompt delivery when needed, is accompanied with IACS class test Certificates of the Classification Society of your interest which are obtainable by the Society in question upon presence of its surveyor during the test, guaranteeing top quality materials.

We are able to give our customers a prompt and complete service in the supply of guaranteed certified accessories of studlink chains and anchors for naval marine uses as well as for buoy moorings and offshore platforms.

We serve all types of vessels in greek ports and oversea

In our testing facilities of 250 tons capacity and 32m free test length, approved for accuracy by the classification Societies, we undertake on your account tests of specimens and materials.

Adequate attachments for tests of anchors up to 15 tons and anchor chains up to the max capacity of 2452 kN (breaking test of links or proof test of full length) are available for our clients.



HIGH HOLDING POWER

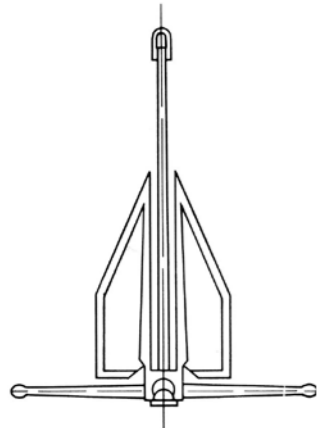

DANFORTH

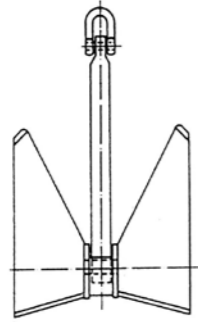

POOL - TW

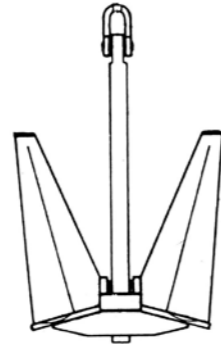

POOL - N

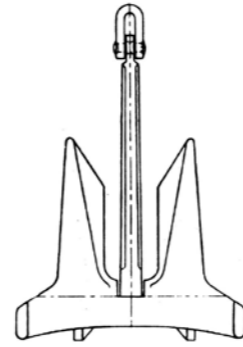

AC 14

STOCKLESS (NORMAL POWER)

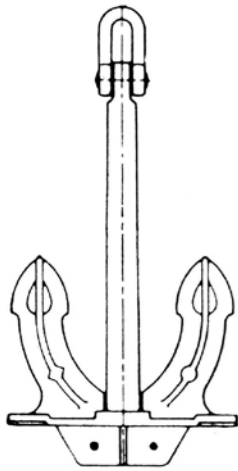

UNION

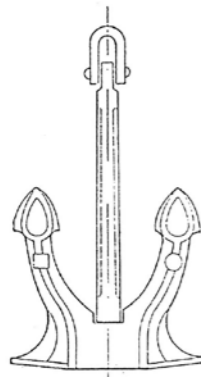

SPEC

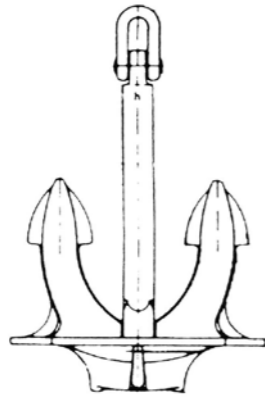

HALL



TECHNICAL DATA

PROOF LOAD TESTS FOR ANCHORS							
Weight of Anchor kg	Proof Load kg	Weight of Anchor kg	Proof Load kg	Weight of Anchor kg	Proof Load kg	Weight of Anchor kg	Proof Load kg
50	2370	900	18600	3600	54800	6900	80700
55	2570	950	19500	3700	55800	7000	81300
60	2760	1000	20300	3800	56800	7200	82600
65	2950	1050	21200	3900	57800	7400	83800
70	3130	1100	22000	4000	58800	7600	85000
75	3300	1150	22800	4100	59800	7800	86100
80	3460	1200	23600	4200	60700	8000	87000
90	3700	1250	24400	4300	61600	8200	88100
100	3990	1300	25200	4400	62500	8400	89200
120	4520	1350	26000	4500	63400	8600	90300
140	5000	1400	26700	4600	64300	8800	91400
160	5430	1450	27500	4700	65100	9000	92400
180	5850	1500	28300	4800	65800	9200	93400
200	6250	1600	29800	4900	66600	9400	94400
225	6810	1700	31300	5000	67400	9600	95300
250	7180	1800	32700	5100	68200	9800	96200
275	7640	1900	34200	5200	69000	10000	97100
300	8110	2000	35600	5300	69800	10500	99300
325	8580	2100	36900	5400	70500	11000	101500
350	9050	2200	38300	5500	71300	11500	103600
375	9520	2300	39600	5600	72000	12000	105700
400	9980	2400	40900	5700	72700	12500	107800
425	10500	2500	42200	5800	73500	13000	109900
450	10900	2600	43500	5900	74200	13500	111900
475	11400	2700	44700	6000	74900	14000	113900
500	11800	2800	45900	6100	75500	14500	115900
550	12700	2900	47100	6200	76200	15000	117700
600	13500	3000	48300	6300	76900	15500	119500
650	14300	3100	49400	6400	77500	16000	120900
700	15200	3200	50500	6500	78200	16500	122200
750	16100	3300	51600	6600	78800	17000	123500
800	16900	3400	52700	6700	79400	17500	124700
850	17800	3500	53800	6800	80100	18000	125900



STUD LINK CHAIN CABLES

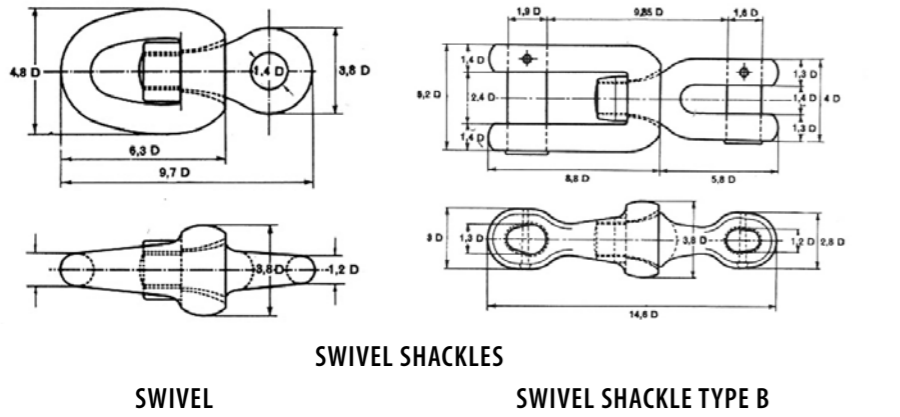
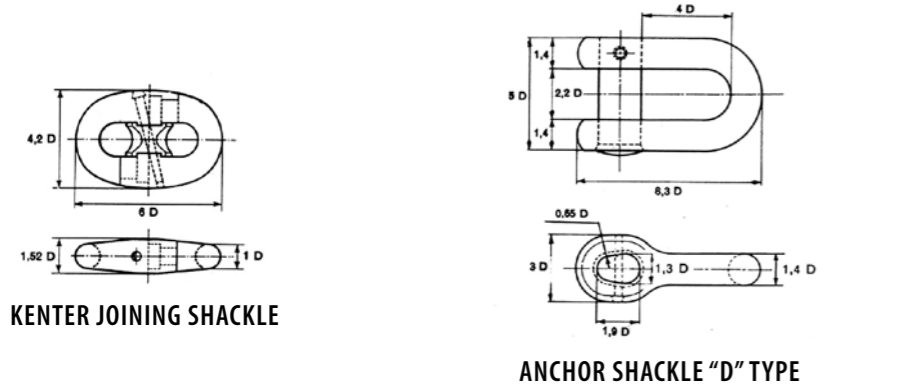
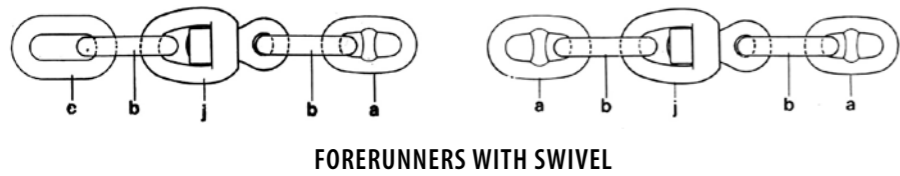
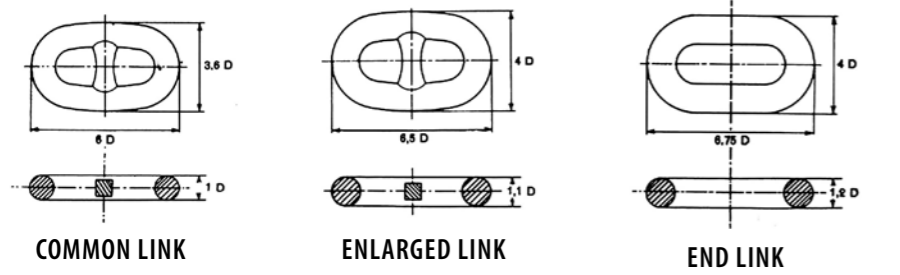

Ship chain proof and minimum breaking loads

Chain Diameter mm	GRADES						Minimum Weight kg per length of 27,5 m
	PROOF LOAD			MINIMUM BREAKING LOAD			
	Grade 1 KN	Grade 2 KN	Grade 3 KN	Grade 1 KN	Grade 2 KN	Grade 3 KN	
16	76	107	150	107	150	216	160
17,5	89	127	179	127	179	256	190
19	105	150	211	150	211	301	225
20,5	123	175	244	175	244	349	265
22	140	200	280	200	280	401	300
24	167	237	332	237	332	476	360
26	194	278	389	278	389	556	420
28	225	321	449	321	449	642	490
30	257	368	514	368	514	735	565
32	291	417	583	417	583	833	635
34	328	468	655	468	655	937	720
36	366	523	732	523	732	1050	800
38	406	581	812	581	812	1160	895
40	448	640	896	640	896	1280	995
42	492	703	981	703	981	1400	1100
44	538	769	1080	769	1080	1540	1200
46	585	837	1170	837	1170	1680	1320
48	635	908	1280	908	1280	1810	1440
50	686	981	1370	981	1370	1960	1560
52	739	1060	1480	1060	1480	2110	1675
54	794	1140	1590	1140	1590	2270	1820
56	851	1220	1710	1220	1710	2430	1935
58	909	1290	1810	1290	1810	2600	2075
60	969	1380	1940	1380	1940	2770	2220
62	1030	1470	2060	1470	2060	2940	2365
64	1100	1560	2190	1560	2190	3130	2550
66	1160	1660	2310	1660	2310	3300	2695
68	1230	1750	2450	1750	2450	3500	2890
70	1290	1840	2580	1840	2580	3690	3030
73	1390	1990	2790	1990	2790	3990	3290
76	1500	2150	3010	2150	3010	4300	3550
78	1580	2260	3160	2260	3160	4500	3755
81	1690	2410	3380	2410	3380	4820	4035
84	1810	2580	3610	2580	3610	5160	4395
87	1920	2750	3850	2750	3850	5500	4760
90	2050	2920	4090	2920	4090	5840	5005
92	2130	3040	4260	3040	4260	6080	5200
95	2260	3230	4510	3230	4510	6440	5570
97	2340	3350	4680	3350	4680	6690	5760
100	2470	3530	4940	3530	4940	7060	6130
102	2560	3660	5120	3660	5120	7320	6505
105	2700	3860	5390	3860	5390	7700	6885
107	2790	3980	5570	3980	5570	7960	7140
111	2970	4250	5940	4250	5940	8480	7715
114	3110	4440	6230	4440	6230	8890	8085
117	3260	4650	6510	4650	6510	9300	8445
120	3400	4860	6810	4860	6810	9720	9110
122	3500	5000	7000	5000	7000	9990	9240
124	3600	5140	7200	5140	7200	10280	9700
127	3750	5350	7490	5350	7490	10710	10040
130	3900	5570	7800	5570	7800	11140	10420
132	4000	5720	8000	5720	8000	11420	10910
137	4260	6080	8510	6080	8510	12160	11720
142	4520	6450	9030	6450	9030	12910	12515
147	4790	6840	9560	6840	9560	13660	13295
152	5050	7220	10100	7220	10100	14430	14695
157	5320	7600	10640	7600	10640	15200	15475
162	5590	7990	11170	7990	11170	15970	16210

For updated information please check regularly our website <http://www.katradis.com/anchors-chains>

VESSEL DECK EQUIPMENT

KATRADIS company supplies for many years a wide range of deck equipment. We keep stock in our premises in Piraeus of various equipment for urgent needs and we can also supply worldwide through our partners / makers in Europe & Asia.

KATRADIS VEP can provide deck equipment such as Bollards, rollers, chocks, chain stoppers, smit brackets etc. which are manufactured according to OCIMF, ISO, JIS, DIN or any other Standards or customer's specifications. The current catalogue includes the equipment which we mainly supply accompanying them with BV certificate. Of course we can provide any third party class certificate (BV, LR, ABS, etc.) according to the client's requisition.

Panama Chocks - Deck Mounting and BLW

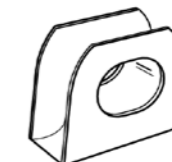

Twin, Single and Cross Bitt Bollards, Tug Escort Bollards, Cruciform Bollards

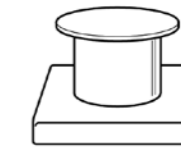
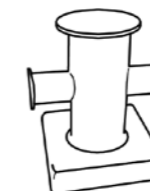
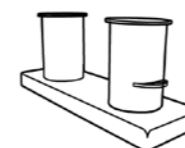

Rollers - Fairlead

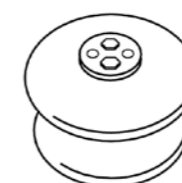

Chain Stoppers and Bulwark Chocks (Emergency Towing System)

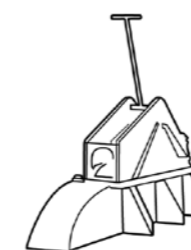

Smit Brackets

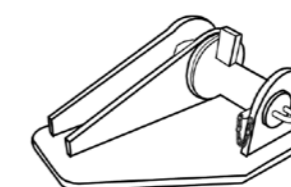

JIS F - 2017 Panama Chocks Type AC

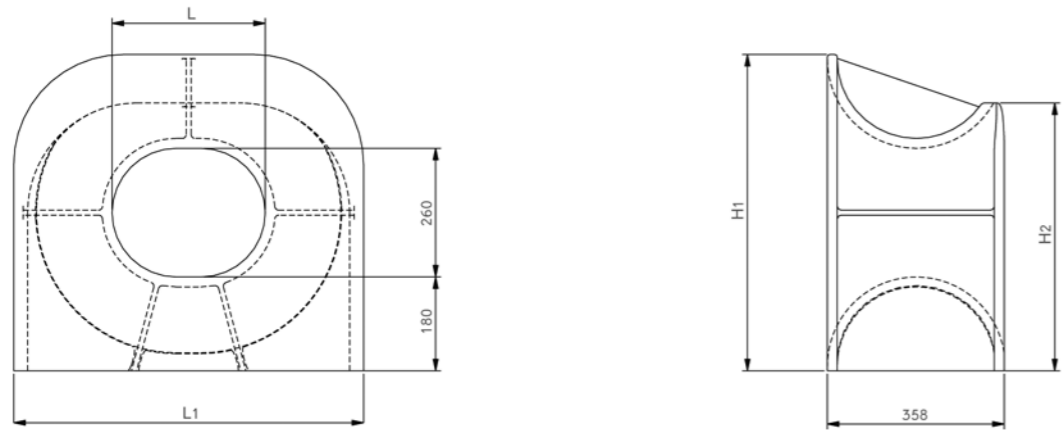

NOM. SIZE	DIMENSIONS (m.m.)				MASS (Kg)
	L	L1	H1	H2	
310	310	708	639	541	253
360	360	760	640	542	289
400	400	804	642	545	323
450	450	856	643	547	351
500	500	908	644	549	395

Panama Bow chock - EU Type - Deck Mounting

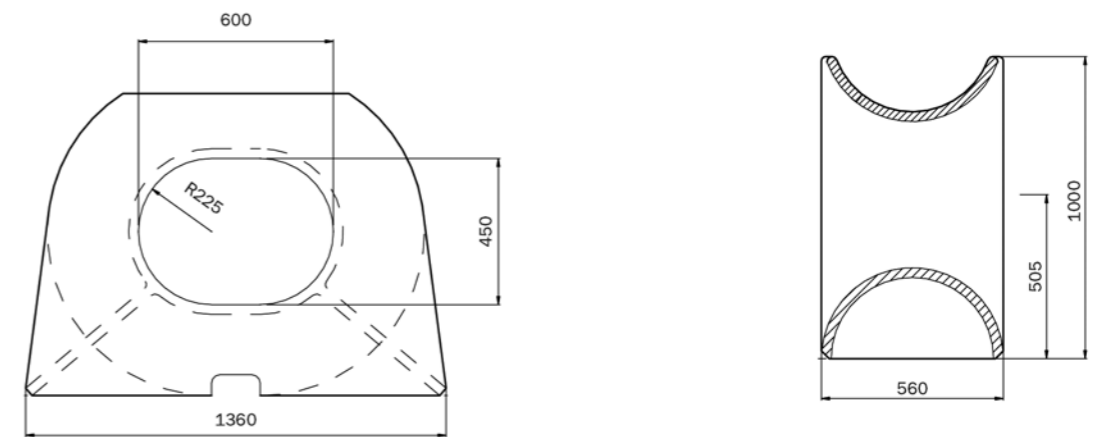

NOM. SIZE	DIMENSIONS (m.m.)					MASS (kgr.)
	A	B	C	D	E	
600x450	600	450	1360	1000	560	740

JIS F - 2017 Panama Chocks Type BC

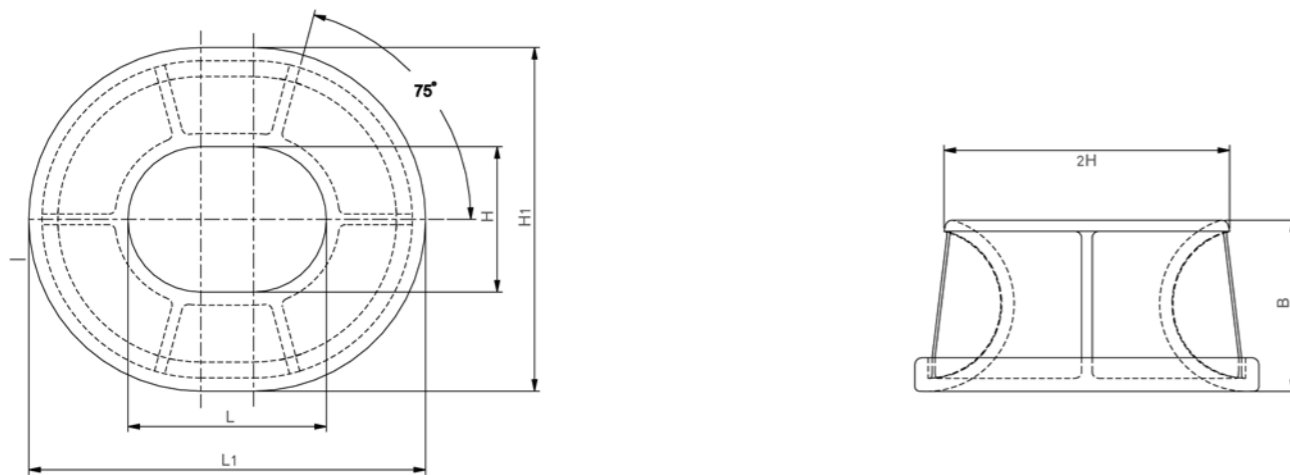

NOM. SIZE	DIMENSIONS (m.m.)					MASS (Kg)
	L	L2	L3	H1	H2	
310	310	734	652	684	462	276
360	360	788	701	688	464	305
400	400	832	750	692	470	344
450	450	886	802	696	474	385
500	500	940	854	700	478	422

JIS F - 2005 Closed Chocks Deck Mounting

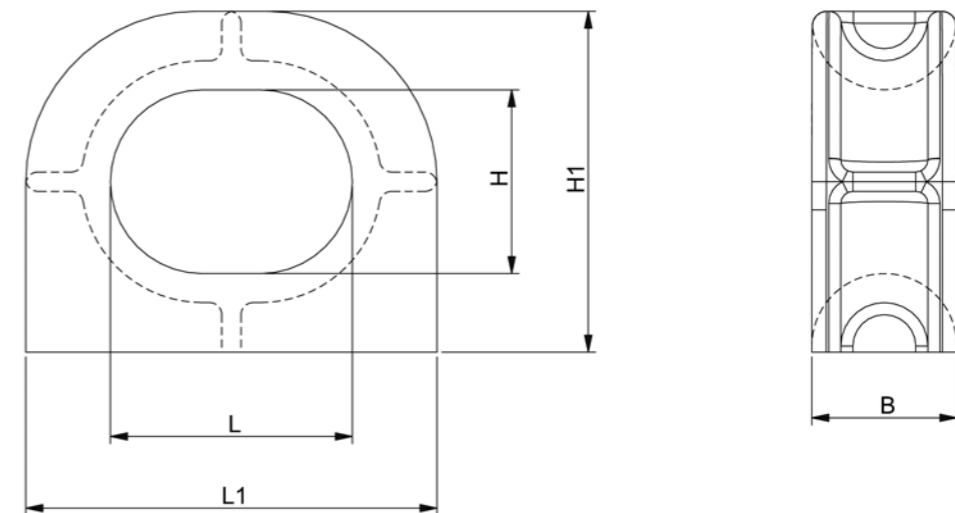

NOM. SIZE	DIMENSIONS (m.m.)					MASS (kgr.)	Dia. of Wire Rope (mm)
	L	L1	B	H	H1		
100	100	170	60	76	141	4	14
150	150	250	90	110	205	11	16
200	200	340	120	150	280	24	18
250	250	434	160	200	372	48	20
300	300	528	200	250	464	82	22
350	350	600	220	250	485	103	24
400	400	672	240	250	506	136	26
450	450	746	260	250	528	184	30
500	500	820	280	250	550	232	36

JIS F - 2001 Double Bitt Bollard

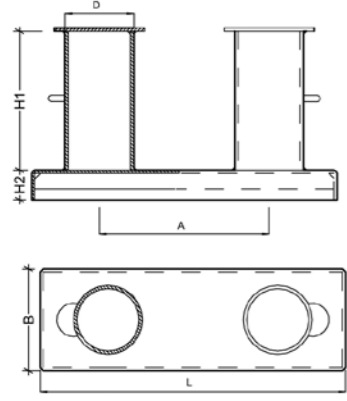

NOM. SIZE	DIMENSIONS (m.m.)						MBL ROPE (ton)	MASS (kgr.)
	D	H1	A	B	L	H2		
100	114	150	250	165	445	50	3	19
125	139	190	315	195	540	60	4	29
160	165	250	400	225	670	70	5	45
200	216	300	500	290	860	85	8	80
250	267	380	630	360	1065	100	12	139
315	318	480	800	430	1300	125	20	261
355	355	530	890	480	1475	145	26	361
400	406	600	1000	550	1630	160	32	502
450	457	680	1130	620	1840	170	39	685
500	508	750	1250	690	2040	190	46	911
560	558	830	1380	750	2240	210	56	1208
630	609	940	1570	820	2510	225	70	1600
710	711	1050	1750	960	2840	260	82	2252
800	812	1200	2000	1100	3240	295	100	3071



Twin bollard ISO-13795, Type B

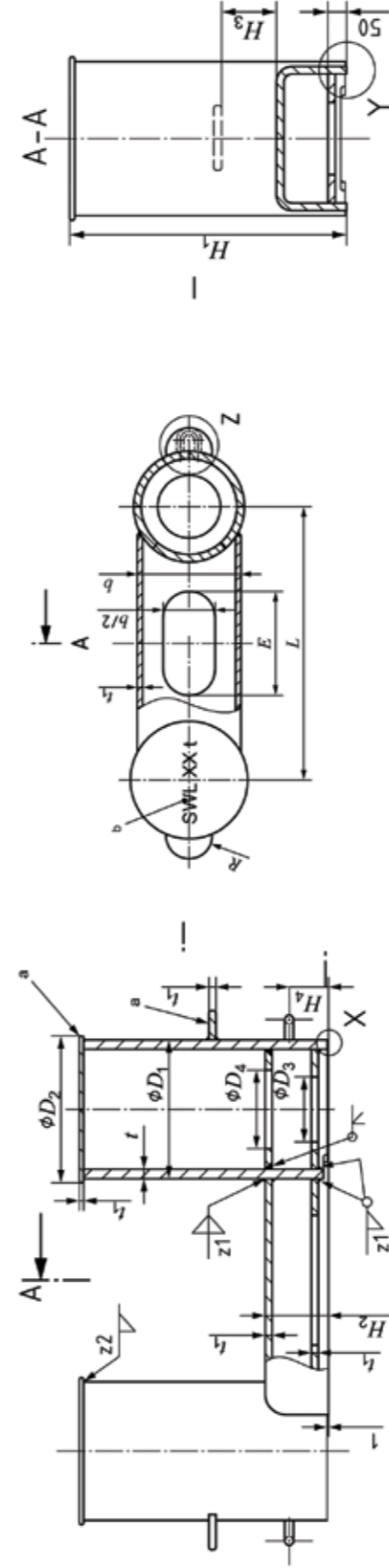

Nominal size D_n	D_1	D_2	D_3	D_4	H_1	H_2	H_3	H_4	b	L	E	f	f_1	f_2	R	Welding leg length ^a		SWL ^b				Calculated weight ^c (kg)		
																z_1	z_2	For mooring purposes (Figure-of-eight belay)		For towing purposes (Eye splice)				
																		(kN)	(t)	(kN)	(t)			
150	165.2	185	-	80	330	90	70	60	155	400	-	8.0	6	6	40	3.5	3.5	54	5.5	49	5.0	383	10	29
200	216.3	240	-	130	395	115	70	60	205	500	-	8.0	6	6	50	3.5	3.5	82	8.4	65	6.7	579	13	46
250A	267.4	290	-	160	505	135	90	75	250	630	-	12.0	9	8	60	5.5	4	156	16	134	14	1315	27	107
250B	267.4	290	-	160	505	135	90	75	250	630	-	10.0	8	7	60	5.5	4	127	13	108	11	215	22	91
300A	318.5	340	150	185	600	150	110	85	290	800	300	21.5	16	9	70	10.5	4	332	34	306	31	3365	62	281
300B	318.5	340	150	185	600	150	110	85	290	800	300	12.0	9	9	70	10.5	4	186	19	161	16	352	36	166
350A	355.6	380	170	200	685	175	130	105	340	890	350	26.0	19	11	80	12.5	5	443	45	418	43	5062	85	431
350B	355.6	380	170	220	685	175	130	105	340	890	350	14.0	10	9	80	7	4	244	25	216	22	2855	50	241
400A	406.4	430	190	230	730	185	145	115	380	1000	380	26.0	20	13	85	12.5	6	594	61	521	53	6632	106	570
400B	406.4	430	190	250	730	185	145	115	380	1000	380	15.0	11	11	85	8	5	326	33	269	27	3816	67	322
450A	457.2	480	210	265	770	195	160	120	425	1100	410	29.0	21	14	90	12	7	753	77	612	62	8201	124	712
450B	457.2	480	210	285	770	195	160	120	425	1100	410	14.5	11	11	90	8	7	382	39	292	30	4483	78	379
500A	508.0	530	235	295	830	230	200	150	480	1250	460	32.0	23	16	100	12.5	8	992	101	757	77	10928	164	960
500B	508.0	530	235	320	830	230	200	150	480	1250	460	14.5	11	11	100	8	5	457	47	326	33	5474	93	465
550A	556.8	580	255	330	900	270	200	180	520	1380	540	31.0	22	16	110	11.5	8	1131	115	812	83	12635	165	1123
550B	556.8	580	255	350	900	270	200	180	520	1380	540	21.0	16	11	110	11.5	5	761	80	541	55	9280	169	767
600	609.4	630	280	365	950	300	200	200	560	1550	600	33.0	23	16	120	11.5	8	1401	143	948	97	15539	193	1391

^a Welding with chamfering is available based on the same welding volume/strength.
^b The SWL is the maximum applicable rope tension.
 The SWLs shown in this table are for reference only. These are based on the loadings as mentioned in Annex A.
 The calculated weight is for reference only.

Strong Point with one stud

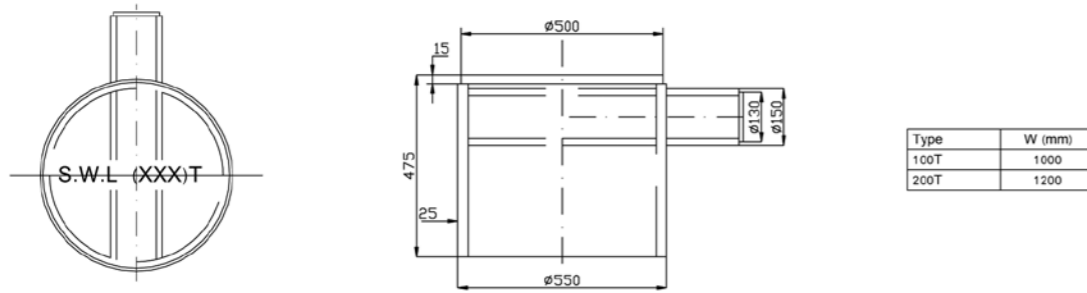

Tug Escort Bollard

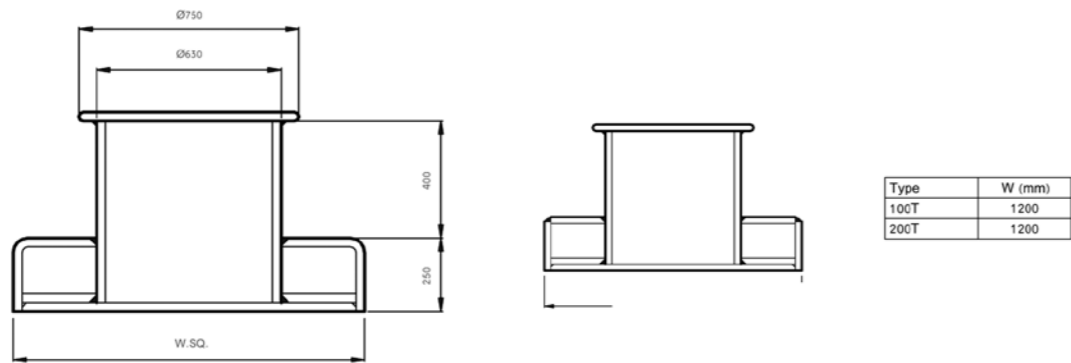

JIS F - 2804 Cross Bitt Bollard

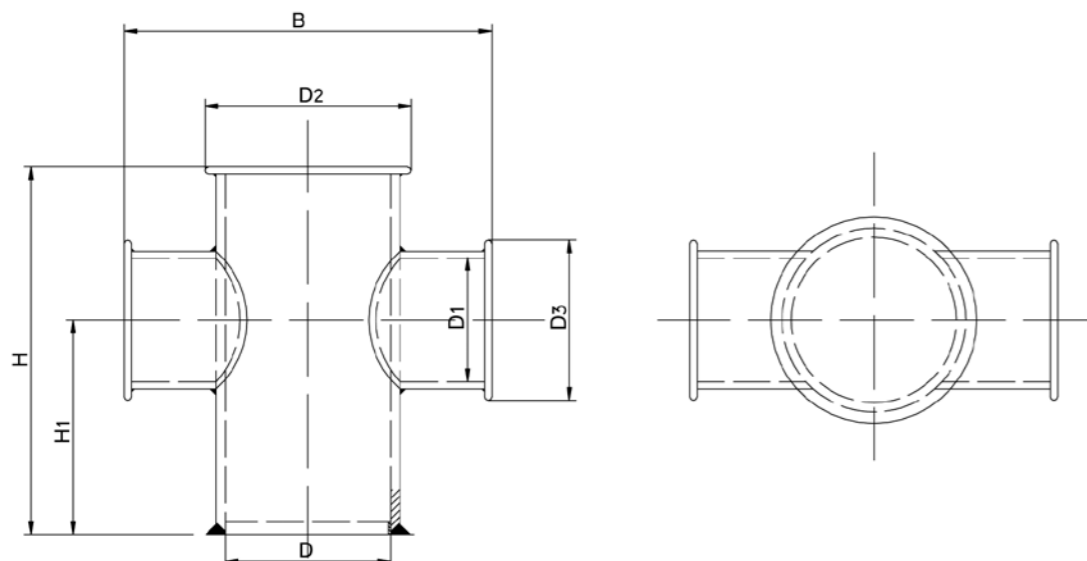

NOM. SIZE	DIMENSIONS (m.m.)							MASS (Kgr)	WIRE ROPE DIA
	H	H1	B	D	D1	D2	D3		
150	480	280	460	165	114	206	158	33	16
200	560	320	520	216	165	256	206	60	22
250	640	360	610	267	216	308	256	102	28
300	680	380	660	318	267	360	308	154	34
350	720	420	720	355	267	400	312	186	38

JIS F - 2014 Fairlead Roller

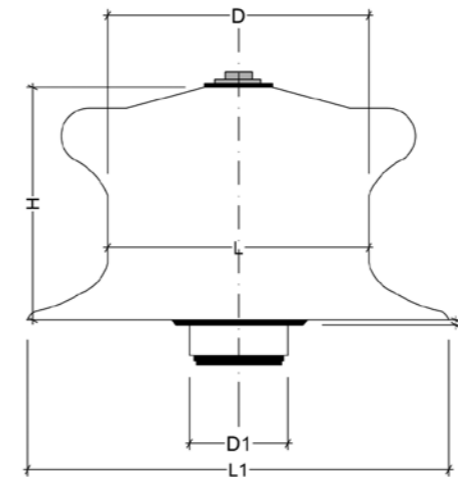

NOM. SIZE	DIMENSIONS (m.m.)				MASS (kgr.)
	L	L1	H	C	
150	150	240	195	3	32.1
200	200	310	235	3	64.6
250	250	380	282	4	108
300	300	440	305	4	159
350	350	500	330	4	235
400	400	560	355	5	336

Fairlead Roller EU Type

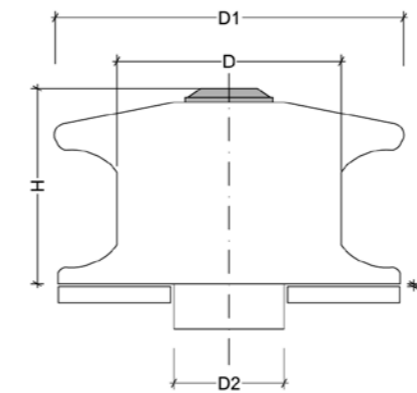

NOM. SIZE	DIMENSIONS (m.m.)				MASS (kgr.)
	D1	D2	H	S	
150	240	90	154	5	25
200	310	115	186	5	50
250	380	135	230	6	92
300	440	155	255	7	127
350	500	175	271	7	168
400	560	195	307	7	252
450	630	210	316	7	310

Roller fairlead (Standard - DIN 81902)

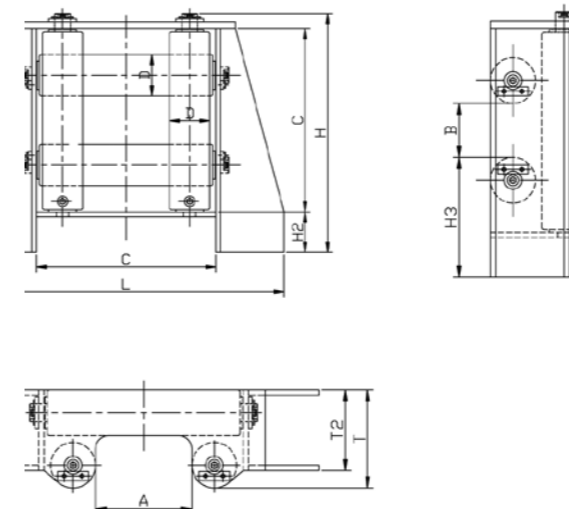

Product Type	Nom Pull (KN)	L (mm)	T (mm)	H (mm)	A (mm)	B (mm)	C (mm)	D (mm)	T2 (mm)	H2 (mm)	H3 (mm)	Weight (Kg)
FA-01	10	460	130	348	120	80	260	60	120	70	160	30
FA-02	20	640	174	464	180	100	364	82	160	80	212	68
FA-03	30	800	219	579	220	120	454	102	180	100	267	140
FA-05	50	900	264	676	250	140	524	127	240	120	312	251
FA-08	80	1000	290	757	280	150	580	140	260	140	355	382
FA-12	120	1200	368	876	300	160	680	178	320	150	410	657
FA-16	160	1300	400	948	320	169	732	194	350	170	452	827
FA-20	200	1350	500	1082	340	180	856	244	450	180	518	1193
FA-32	320	1700	608	1355	400	250	1026	298	550	220	608	2200

Bulwork Chocks SWL-250T

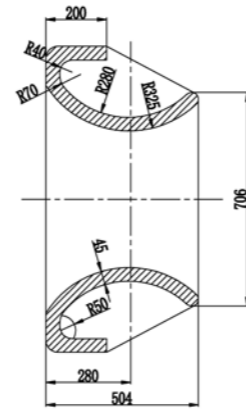
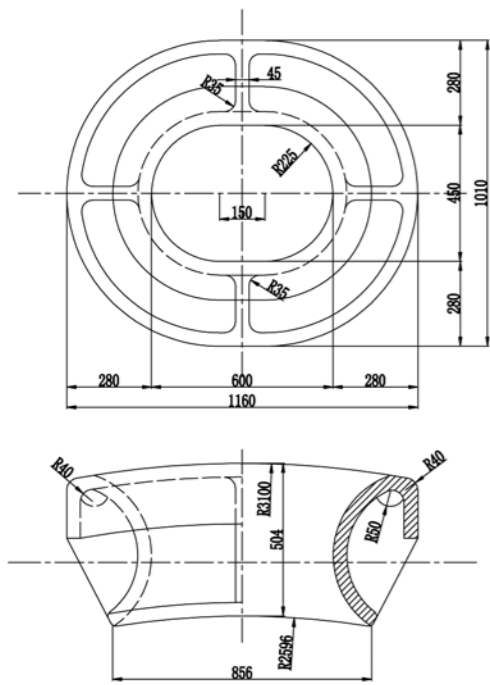

Chain Stoppers

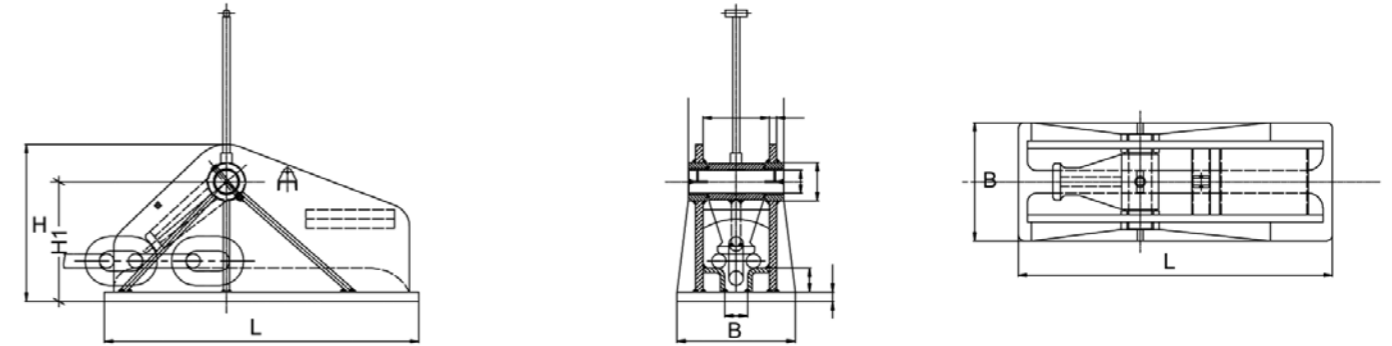

SWL	DIMENSIONS (m.m.)				MASS (Kgr)
	L	B	H	H1	
250T	1,800	640	850	648	1,528
350T	1,700	640	850	648	1,728

Bulwork Chocks SWL-350T

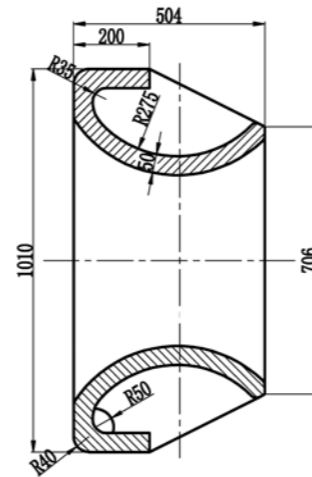
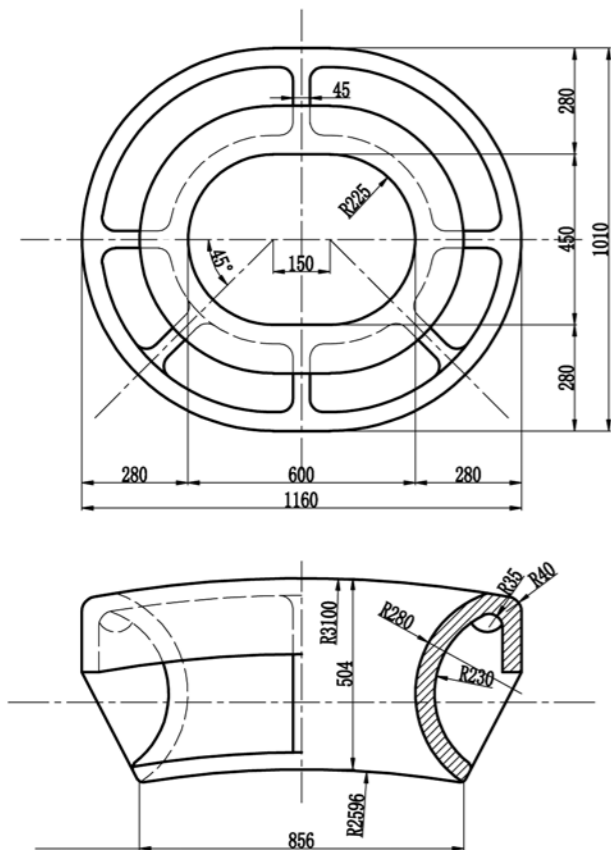

Smit Bracket OCIMF Type

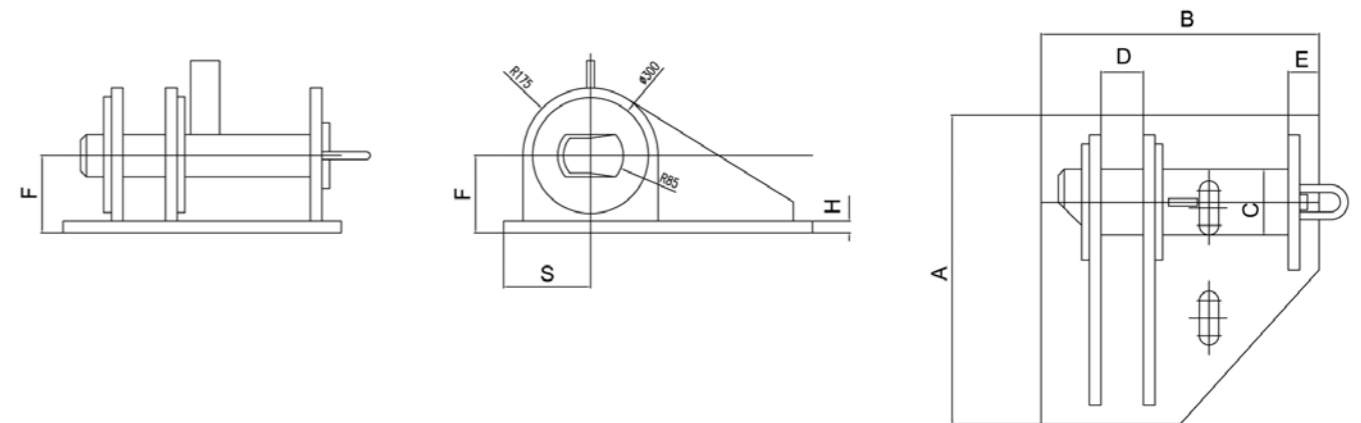

Nominal Cable Dia (mm)	Dimensions (mm)								Mass (kgr)
	A	B	C	D	E	F	H	S	
54	625	600	125	80	100	175	30	123	184
76	800	720	170	110	110	200	30	175	278



CERTIFICATE OF APPROVAL

This is to certify that the Quality Management System of:
KATRADIS MARINE ROPES INDUSTRY S.A.
11, Psaron
186 48, Drapetsona
Greece

has been approved by Lloyd's Register Quality Assurance to the following Quality Management System Standard:

BS EN ISO 9001:2008

The Quality Management System is applicable to:
Design, Production and Sales of Synthetic Ropes and Anodes. Trading of Marine Paints, Anchors, Anchor Chains and their Accessories, Safety Ladders, Fenders and Bollards for Ports.

This certificate is valid only in association with the certificate schedule bearing the same number on which the locations applicable to this approval are listed.

Approval Certificate No: PIR0362324	Original Approval: 26 July 2006
	Current Certificate: 06 August 2015
	Certificate Expiry: 05 August 2018

Issued by: Hellenic Lloyd's S.A. for and on behalf of Lloyd's Register Quality Assurance



Approval Certificate No: PIR0362324
 87, Akti Miaouli, 185 38, Piraeus, Greece
 For and on behalf of 1 Trinity Park, Bickenhill Lane, Birmingham, B37 7ES, United Kingdom
 This approval is carried out in accordance with the LRQA assessment and certification procedures and monitored by LRQA.
 The use of the UKAS Accreditation Mark indicates Accreditation in respect of those activities covered by the Accreditation Certificate Number 001 Macro revision 14

Lloyd's Register Group Limited, its affiliates and subsidiaries, including Lloyd's Register Quality Assurance Limited (LRQA), and their respective officers, employees or agents are, individually and collectively, referred to in this clause as 'Lloyd's Register'. Lloyd's Register assumes no responsibility and shall not be liable to any person for any loss, damage or expense caused by reliance on the information or advice in this document or howsoever provided, unless that person has signed a contract with the relevant Lloyd's Register entity for the provision of this information or advice and in that case any responsibility or liability is exclusively on the terms and conditions set out in that contract.



CERTIFICATE OF APPROVAL

This is to certify that the Quality Management System of:

KATRADIS VEP S.A.
11, Psaron Street
186 48, Drapetsona
Greece

has been approved by Lloyd's Register Quality Assurance to the following Quality Management System Standard:

BS EN ISO 9001:2008

The Quality Management System is applicable to:
Fabrication of wire ropes and wire rope slings. Sales of wire ropes, wire rope slings, chains, relevant marine accessories, fixed deck equipment, moving and marking buoys, light towers, antipollution materials, safety ladders, fenders and bollards for ports.

Approval Certificate No: PIR0362325	Original Approval: 07 August 2006
	Current Certificate: 22 August 2015
	Certificate Expiry: 21 August 2018

Issued by: Hellenic Lloyd's S. A. for and on behalf of Lloyd's Register Quality Assurance Limited



87, Akti Miaouli, 185 38, Piraeus, Greece
 For and on behalf of 1 Trinity Park, Bickenhill Lane, Birmingham, B37 7ES, United Kingdom
 This approval is carried out in accordance with the LRQA assessment and certification procedures and monitored by LRQA.
 The use of the UKAS Accreditation Mark indicates Accreditation in respect of those activities covered by the Accreditation Certificate Number 001 Macro revision 14

Lloyd's Register Group Limited, its affiliates and subsidiaries, including Lloyd's Register Quality Assurance Limited (LRQA), and their respective officers, employees or agents are, individually and collectively, referred to in this clause as 'Lloyd's Register'. Lloyd's Register assumes no responsibility and shall not be liable to any person for any loss, damage or expense caused by reliance on the information or advice in this document or howsoever provided, unless that person has signed a contract with the relevant Lloyd's Register entity for the provision of this information or advice and in that case any responsibility or liability is exclusively on the terms and conditions set out in that contract.



The KATRADIS GROUP OF COMPANIES in its continued effort for better customer service and support is pleased to announce that all of its affiliated establishments maintain stocks of KATRADIS products ready for immediate delivery.

Read more: <http://www.katradis.com>



Pioneers in quality perfection

Established in 1936 in Piraeus, Greece, the Katradis Group of Companies is one of the most prominent organizations in the shipping industry. Over the years, the Katradis Group has developed expertise in the design, development and manufacture of high quality synthetic mooring ropes. Our wide range of products includes ropes made with UHMWPE, Aramid, LCP (Liquid Crystal Polymer), Polypropylene, Nylon, Polyester and Mixed / Dual Fiber ropes, in single and double braided constructions.

The Katradis Group of Companies also supplies steel wire ropes, zinc and aluminum anodes, anchors and stud link anchor chain cables, container fittings, alloy steel chain slings, wire and synthetic rope lifting slings and lashing webbings, port development equipment, rubber dock fenders, buoys, floating marinas, bollards, oil booms, vessel deck equipment, protective coatings (SHARK Marine Paints) and testing services in our LR Approved Testing Establishment.



We serve worldwide!

With the support of an extensive global network of affiliated establishments, agents, suppliers and representatives, we provide our customers with immediate service around the world.

Katradis Global Network

Africa: Egypt (Alexandria, Port Said, Suez) • South Africa (Durban, Cape Town) • Asia: Singapore (Singapore) | Korea (Pusan) | China (Hong Kong, Shanghai, Qingdao, Zhenjiang & other ports) • Europe: Belgium (Antwerp, Zeebrugge) | Germany (Hamburg) | Netherlands (Rotterdam, Amsterdam) | Spain (Algeciras, Cadiz, Las Palmas) | Turkey (Istanbul) | Bulgaria (Varna) | Greece (all ports) | Cyprus (all ports) • Middle East: U.A.E. (Fujairah, Dubai) • North America: Canada (Montreal) | USA (Houston, New Orleans, New York) • Central America: Panama (Panama) • South America: Brazil (Santos, Rio de Janeiro, Vitoria, Paranagua, Sepetiba, Itagua) • Australia (Brisbane, Sydney, Melbourne, Adelaide, Fremantle and Darwin)





KATRADIS GROUP OF COMPANIES

**UHMWPE, Aramid & Mixed Ropes for LNG / LPG Carriers and Tankers - Steel Wire Ropes - Sacrificial Anodes
Anchors & Anchor Chains - Port Development Equipment - Vessel Deck Equipment**

11, Psaron str., 186 48 Piraeus, Greece, T: +30 2104060300 - F: +30 2104626268 & +302104619631, E: info@katradis.com - www.katradis.com